

Tauro Deck Oven

Direct Venting Requirements

Installation requirements

It is recommended that the oven uses a type B vent system or a commercial hood for the purposes of heat removal when using the oven.

- The oven is used exclusively for baking pizza and/or bread.
- There is no combustion within the oven, as it is 100% electric
- The vent of the oven includes a compartment that will reduce 60% of the heat and steam dispersion.

If you need to install a fan extractor, it must be between 240 and 290 CFM.

We at Italiana FoodTech Inc. declare to have measured the temperature of the steam at the chimney collar when it exits the baking chamber for ovens with 1-3 chambers. The table below shows the data gathered from these measurements.

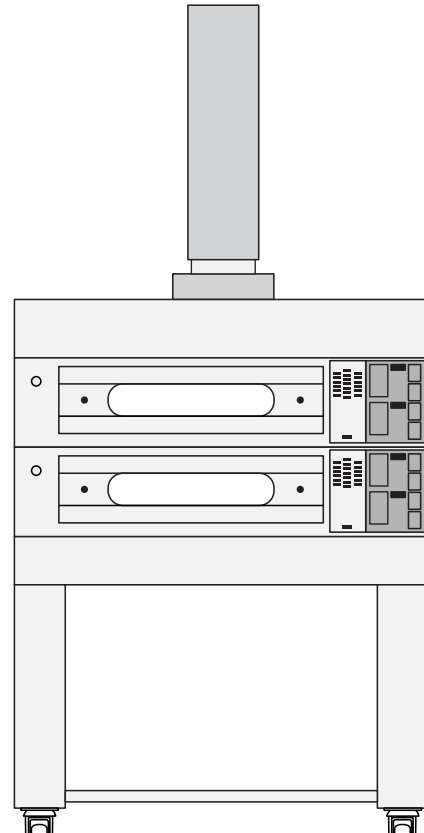

Tauro Oven	1 Deck	2 Deck	3 Deck
Interior (°F/°C)	Chimney Collar (°F/°C)	Chimney Collar (°F/°C)	Chimney Collar (°F/°C)
392/200	161/72	167/75	176/80
482/250	168/76	181/83	197/92
572/300	181/83	208/98	224/107
662/350	201/94	233/112	253/123
716/380	206/97	240/116	269/132

Venting is subject to the local authority. Local building codes take precedence. Use a qualified professional to design and install your venting system. Check with local authorities for specific code requirements.

Tauro Deck Oven

Indirect Venting Requirements

Installation requirements

It is recommended that the oven be positioned under commercial hood for the purposes of heat removal when using the oven without a direct vent.

- The oven is used exclusively for baking pizza and/or bread.
- There is no combustion within the oven, as it is 100% electric
- The vent of the oven includes a compartment that will reduce 60% of the heat and steam dispersion.

If you need to install a fan extractor, it must be between 240 and 290 CFM.

We at Italiana FoodTech Inc. declare to have measured the temperature of the steam at the chimney collar when it exits the baking chamber for ovens with 1-3 chambers. The table below shows the data gathered from these measurements.

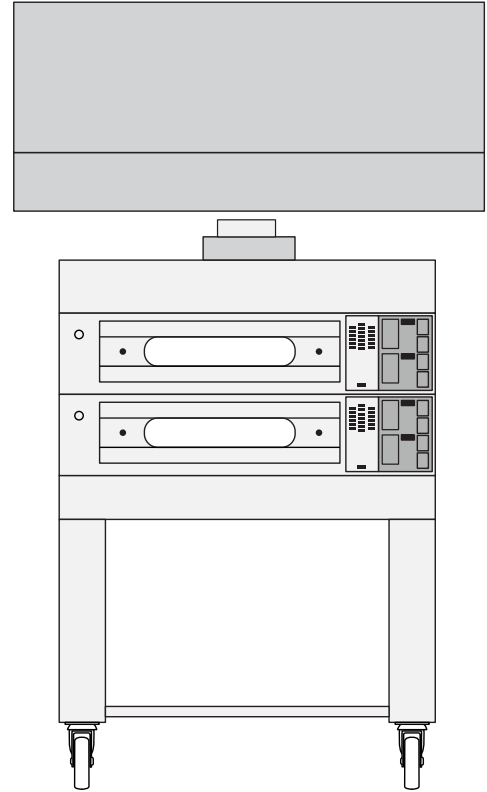

Tauro Oven	1 Deck	2 Deck	3 Deck
Interior (°F/°C)	Chimney Collar (°F/°C)	Chimney Collar (°F/°C)	Chimney Collar (°F/°C)
392/200	161/72	167/75	176/80
482/250	168/76	181/83	197/92
572/300	181/83	208/98	224/107
662/350	201/94	233/112	253/123
716/380	206/97	240/116	269/132

Venting is subject to the local authority. Local building codes take precedence. Use a qualified professional to design and install your venting system. Check with local authorities for specific code requirements.