

OPERATOR'S MANUAL

CT CLASSIC™

CTC6-10E	CTC6-10G
CTC10-10E	CTC10-10G
CTC7-20E	CTC7-20G
CTC10-20E	CTC10-20G
CTC20-10E	CTC20-10G
CTC20-20E	CTC20-20G



⚠ WARNING

To prevent personal injury, death or property damage:
Do not store or use gasoline or other flammable vapors or liquids in the vicinity of this or any other appliance.

⚠ WARNING

Improper installation, alteration, adjustment, service, cleaning, or maintenance could result in property damage, severe injury, or death.

Read and understand the installation, operating and maintenance instructions thoroughly before installing, servicing, or operating this equipment.



This manual covers the following CTC series models:

Boiler-Free Models	Steam Generator Models
6-10E, 6-10G	6-10EB
10-10E, 10-10G	10-10EB
7-20E, 7-20G	7-20EB
10-20E, 10-20G	10-20EB
20-10E, 20-10G	20-10EB
20-20E, 20-20G	20-20EB

Please post the following instructions in a prominent location in the event the user smells gas.

DANGER	
	<p>Before starting the appliance, make certain you do not detect the odor of gas.</p> <p>If you smell gas:</p> <ul style="list-style-type: none"> • Shut off the gas supply immediately. • Do not attempt to light any appliance. • Do not touch any electrical elements. • Extinguish any open flame. • Evacuate the area. • Use a telephone outside the property and immediately contact your gas supplier. • If unable to contact your gas supplier, contact the fire department.

Enjoy your Alto-Shaam Combi Oven!

The combi oven combines a steam and convection oven into one versatile unit and can serve a variety of cooking functions. Alto-Shaam's combi ovens allow chefs to control humidity and temperature separately, with powerful results. The same oven can be used to dehydrate vegetables, roast pork, steam rice, smoke brisket and bake loaves of bread.

The PROtouch™ recipe management system with one-touch cooking provides complete control over the oven, allowing chefs and foodservice employees to select pre-programmed

recipes for maximum consistency. To store and secure important information, a HACCP data system pairs up with an onboard USB port, so settings can be downloaded and saved for the future.

When it's time to clean up, Alto-Shaam's CombiClean Plus™ automated cleaning system saves labor previously spent scrubbing the oven cavity. On the oven's exterior, a PROrinse™ retractable hose gives you spray-washing power without opening the oven door.

Before Use

This guide is provided as an operational aid with step-by-step instructions of the basic functions of the Combitherm oven and additional features of the control.

If this is the first time this oven is being used, or if the oven has just been removed from storage, follow these steps for cleaning:

1. Remove all packing material from the appliance.
2. Remove and wash any detachable items such as wire shelves, side racks, pans, and drip trays with hot, soapy water. Dry with a clean, damp lint-free cloth.
3. Remove all visible grease or oil from the appliance.

4. Clean the interior and exterior of the appliance with a mild soap and water solution. Apply the solution with a clean, damp cloth. Do not use commercial or household cleaners that contain ammonia. Wipe with a clean, damp cloth to remove all detergent residue. Dry with a clean, lint-free cloth.
5. Clean the appliance glass with glass cleaner or distilled vinegar.
6. Re-install the side racks and wire shelves – position shelves with the curved end up and toward the rear of the appliance.

The appliance is now ready for operation.

PROTECT YOUR ORIGINAL MANUFACTURER'S WARRANTY, REGISTER ONLINE:

www.alto-shaam.com *Support > Warranty Registration*

Register to ensure prompt resolution of warranty claims



Please register your Alto-Shaam equipment to ensure prompt service in the event of a warranty claim. **You'll automatically be entered into a monthly drawing to win an additional year extended warranty!**

Registering your equipment will allow you to receive notifications about software updates and additional product information.

NOTE: Your personal information will not be shared with any other company.

ALTO-SHAAM 24/7 EMERGENCY REPAIR SERVICE

Call 800-558-8744 to reach our twenty-four hour emergency service call center for immediate access to local authorized service agencies outside standard business hours. The emergency service access is provided

exclusively for Alto-Shaam equipment and is available throughout the United States through Alto-Shaam's toll free number. Emergency service access is available seven days a week, including holidays.



Introduction	3
Safety Procedures	6
Operation	9
Control Panel Identification	9
How To Turn On the Appliance	10
How To Preheat the Appliance	11
Cooking by Probe	11
Cooking by Time	11
Steam Mode Chef Operating Tips	12
Combination Mode Chef Operating Tips	13
Options	14
CombiHood PLUS™ Ventless Hood Option	14
Recipe Guidelines	16
Bakery Items	16
Convenience Product Items	17
Fish & Seafood Items	18
Meats	18
Miscellaneous Foods	19
Poultry	19
Vegetables	20
Cleaning and Preventative Maintenance	21
CombiClean® Cleaning Agents	21
Daily Inspection	22
Weekly Inspection	23
Monthly Inspection	24
Yearly Inspection	25
Preventative Maintenance	28
Sweep Gasket Installation	29
Protecting Stainless Steel Surfaces	31
Cleaning the Oven	32
Probe and Probe Prong Cleaning	32
Roll-In Cart/Food Trolley Cleaning	33
Cleaning Process	33
Troubleshooting	34
Error Codes	34
Limited Warranty	40

Safety Procedures

- The appliance is intended to cook, hold or process foods for the purpose of human consumption. No other use for this appliance is authorized and is therefore considered dangerous. The appliance must not be used to cook food containing flammable materials (such as food with alcohol). Substances with a low flash point can ignite spontaneously and cause a fire.
- The appliance is intended for use in commercial establishments where all operators are familiar with the purpose, limitations, and associated hazards of this appliance. Operating instructions and warnings must be read and understood by all operators and users. Alto-Shaam recommends regular staff training to avoid the risk of accident or damage to the appliance. Operators must also receive regular safety instructions.
- Any troubleshooting guides, component views, and parts lists included in this manual are for general reference only and are intended for use by qualified and trained technicians.
- This manual should be considered a permanent part of this appliance. This manual and all supplied instructions, diagrams, schematics, parts lists, notices, and labels must remain with the appliance if the item is sold or moved to another location.

Knowledge of proper procedures is essential to the safe operation of electrically and/or gas energized equipment. The following signal words and symbols may be used throughout this manual.

DANGER

Indicates a hazardous situation that, if not avoided, will result in death or serious injury.

WARNING

Indicates a hazardous situation that, if not avoided, could result in death or serious injury.

CAUTION

Indicates a hazardous situation that, if not avoided, could result in minor or moderate injury.

NOTICE: Indicates information considered important, but not hazard-related (e.g., messages relating to property damage).

NOTICE: For equipment delivered for use in any location regulated by the following directive: 2012/95/EC WEEE



Do not dispose of electrical or electronic equipment with other municipal waste.

Environmental Conditions

Operational Environmental Conditions

- Before use, appliance must acclimate to room temperature in the environment it is placed — 24 hours is recommended.
- Ambient temperature range of 60°F to 110°F (16°C to 43°C).
- Relative humidity of less than 95% non-condensation.
- Atmospheric pressure range of 17.7" to 31.3" of mercury (50kPa to 106kPa).

- To prevent serious injury, death or property damage, the appliance should be inspected and serviced at least every twelve (12) months by an authorized service partner or trained technician.
- **Only** allow an authorized service partner or trained technician to service or to repair the appliance. Installation or repairs that are not performed by an authorized service partner or trained technician, or the use of non-factory authorized parts, will void the warranty and relieve Alto-Shaam of all liability.
- When working on this appliance, observe precautions in the literature, on tags, on labels attached to or shipped with the appliance and other safety precautions that may apply.
- If the appliance is installed on casters, freedom of movement of the appliance must be restricted so that utility connections (including gas, water, and electricity) cannot be damaged when the appliance is moved. If the appliance is moved, ensure that all utility connections are properly disconnected. If the appliance is returned to its original position, ensure that retention devices and utility connections are properly connected.
- **Only** use the appliance when it is stationary. Mobile appliance racks, mobile plate racks, transport trolleys, and appliances on casters can tip over when being moved over an uneven floor or threshold and cause serious injury.
- **Always** apply caster brakes on mobile appliances or accessories when these are not being moved. These items could move or roll on uneven floors and cause property damage or serious injury.
- Be extremely careful when moving appliances because the food trays may contain hot fluids that may spill, causing serious injury.
- **Always** open the appliance door very slowly. Escaping hot vapors or steam can cause serious injury or death.
- If the gas appliance is installed under an exhaust hood, the hood must be switched **On** when the appliance is in use to avoid the build up of combustion gases. Failure to do so may result in serious injury, death or property damage.
- Accumulations on the main burners of gas appliances can result in firing out of normal sequence. This delayed ignition creates an alarmingly loud sound. If your appliance makes an especially loud noise when starting up, shut down the appliance and call a qualified and trained service technician.
- **Never** place objects near the appliance exhaust vents. This area is hot and could be a potential ignition source for a fire.
- Do not allow objects to block or obstruct the area below the appliance base. This may result in fire, damage to the equipment, or serious injury.
- Do not use the attached hand-held hose to spray anything other than the interior of the appliance compartment.
- Do not use the attached hand-held hose on the surface of a hot cooking compartment. The sudden temperature change can damage the appliance interior. Allow the appliance to cool to a minimum of 150°F (66°C). Failure to observe this precaution can void the warranty.

WARNING



This appliance is not intended for use by persons (including children) with reduced physical, sensory or mental capabilities, or lack of experience and knowledge, unless they have been given supervision concerning use of the appliance by person responsible for their safety.

Children should be supervised to ensure that they do not play with the appliance.

Safety Procedures

⚠ WARNING



To prevent serious personal injury, death, or property damage:

Do not steam clean, hose down or flood the interior or exterior with water or liquid solution of any kind. **Do not** use water jet to clean. Failure to observe this precaution will void the warranty.

WARNING



To prevent **SERIOUS PERSONAL INJURY** or **PROPERTY DAMAGE**:

DO NOT handle pans containing liquid or semiliquid products positioned above the eye level of the operator. Such products may scald and cause serious injury.

WARNING



DO NOT obstruct or block exhaust flues or attach any flue extension that may impede proper burner operation, restrict the exhaust fumes, and cause negative backdraft or the appliance to shut down. Failure to do so may result in serious injury or death.

⚠ WARNING



To prevent **serious personal injury, death,** or **property damage**:

The appliance must be cleaned thoroughly to avoid deposits of grease and or food residue inside the appliance that may catch fire. If fat deposits and/or food waste inside the appliance ignite, shut down the appliance immediately and keep the appliance door closed to extinguish the fire. If further extinguishing is required, disconnect the appliance from the main power and use a fire extinguisher (do not use water to extinguish a grease fire!). Failure to clean the appliance properly invalidates the warranty and relieves Alto-Shaam of all liability.

⚠ CAUTION



To prevent **personal injury** or **property damage**:

Always use hand protection when operating this appliance to avoid burns. Metal parts of this equipment become extremely hot when in operation.

CAUTION



To prevent **INJURY** or **PROPERTY DAMAGE**, make certain the area around the appliance is kept clear of combustible items.

NOTICE: Automatic steam venting is a standard safety feature built into all Combitherm oven models. This feature vents all steam from the oven compartment immediately before cooking time expires or set probe temperature is reached.



Automatic steam venting does not function if the oven door is opened before time expires or when the oven has been set to continuous operation.

NOTICE: Use authorized Combitherm oven cleaner only. Unauthorized cleaning agents may discolor or harm interior surfaces of the oven. Read and understand label and material safety data sheet before using the oven cleaner.

Control Panel Identification

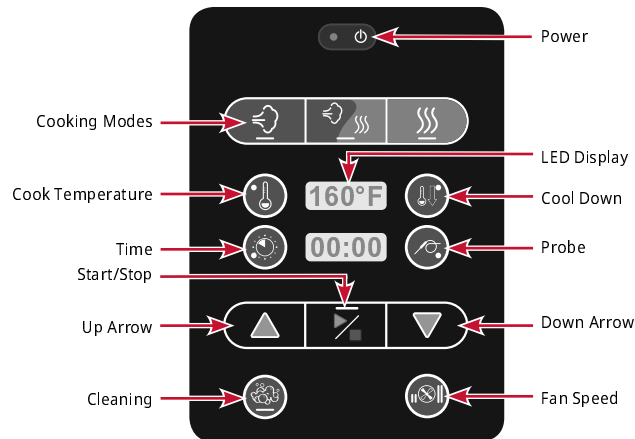

- The **Steam** mode provides the operator with the ability to steam, poach, blanch, or sous vide. This mode will automatically steam at the boiling point of water; quick-steam above the boiling point for faster cooking results; or low temperature steam, below the boiling point, for more delicate products such as pâté, mousse, seafood, or custard.

The **Combination** mode will prove to be the most versatile and widely used mode the Combitherm oven has to offer. It will produce the best possible results on the widest variety of products — all within the shortest period of time. The unique control function of this mode enables the operator to roast or bake with a combination of steam and convection heat. In addition to shorter cooking times, this combination of steam and heat offers less product shrinkage and more moisture retention than obtained in a standard convection oven.

The **Convection** mode operates with hot circulated air within a temperature range of 85°F – 575°F (29°C – 300°C). For many applications, better results may be achieved with the Combination mode; therefore, the operator may want to consider using the Convection mode on a more limited basis.

NOTE: In the event of a power failure, the oven will not operate.

Temperatures below 350°F (177°C) permit high speed fan and low speed fan operation. Temperatures at 350°F (177°C) or higher permit only high speed fan operation.

Oven Cool Down Process:

- Cooking process must be inactive.
- Press the **Cool Down** button until the LED light appears (LED remains on while the appliance is in the Cool Down mode).
- Press **Up** or **Down Arrows** to adjust the cool down temperature.
- The Cook Temperature LED display indicates the cool down temperature.
- The Cool down temperature range is 85°F – 575°F (30°C – 300°C).
- Press the **Start/Stop** button until the LED accepts the selected cool down temperature and initiates the cool down process.
- Open the door to begin the cool down process; the Time LED will display "door" if the door is not open.
- The Cook Temperature LED will display the selected cool down temperature.
- The Time LED will display the current cool down temperature.

Fahrenheit or Celsius Function - Choose Temperature Format:

- The appliance cannot be in a cooking process or a cleaning cycle.
- Press the **Cook Temperature** button, **Up Arrow** and **Down Arrow** buttons simultaneously for 1 second.
- The Cook Temperature LED displays the last C or F value; the display alternates between C and F every 2 seconds.
- Press the **Start/Stop** button when the desired C or F value is displayed.

Operation

How To Turn On the Appliance

Prerequisites

1. Turn on the exhaust hood.
2. Make sure that the water supply to the appliance is turned on.
3. Make sure that the electrical power supply to the appliance is turned on.
4. For gas appliances, make sure the gas supply valve is in the open position.

Steps

1. Press the ON/OFF button .

The ON/OFF indicator glows green.

NOTE: If the appliance has a steam generator, the steam generator fills with water and the appliance heats the water to an initial temperature of 188°F (77°C).

NOTE: To power off the appliance, press and hold the Power button for 5 seconds to initiate the power shut down sequence to the oven.

The oven will not shut down during a cooking cycle.

NOTICE: Accumulations on the main burners can result in firing out of normal sequence. This delayed ignition creates an alarmingly loud sound. If your appliance makes an especially loud noise when starting up, shut down your appliance and call a qualified and trained service technician. In the event of a power failure, the oven will not operate.

DANGER













Before starting the appliance, make certain you do not detect the odor of gas.

If you smell gas:











- Shut off the gas supply immediately.
- Do not attempt to light any appliance.
- Do not touch any electrical elements.
- Extinguish any open flame.
- Evacuate the area.
- Use a telephone outside the property and immediately contact your gas supplier.
- If unable to contact your gas supplier, contact the fire department.

How To Preheat the Appliance

Alto-Shaam recommends preheating the Combitherm® before cooking.

1. Press the **Power** button 
2. Press the desired **Cook Mode** button.  Steam  Combi  Convection
3. Press the **Oven Temperature** button; adjust the temperature with the **Arrow** buttons.   
4. Press the **Cook Time** button; adjust the time with the **Arrow** buttons.   
5. Press the **Start/Stop** button. 



Cooking by Probe

1. Preheat the appliance.
2. Press the desired **Cook Mode** button.  Steam  Combi  Convection
3. Press the **Oven Temperature** button; adjust the temperature with the **Arrow** buttons.   
4. Press the **Probe Temperature** button; adjust the probe temperature with the **Arrow** buttons.   
5. Press the **Fan Speed** button to choose High Speed or Low Speed. 
6. Load food into the appliance and insert probe into the food.
7. Press the **Start/Stop** button. 

CAUTION

Burn hazard. Hot cooking chamber generates steam which escapes when oven door is opened. To avoid steam burns, open oven door slowly and stand away from door opening.

Cooking by Time

1. Preheat the appliance.
2. Press the desired **Cook Mode**.  Steam  Combi  Convection
3. Press the **Oven Temperature** button; adjust the temperature with the **Arrow** buttons.   
4. Press the **Cook Time** button; adjust the time with the **Arrow** buttons.   
5. Press the **Fan Speed** button to choose High Speed or Low Speed. 
6. Load food into the appliance.
7. Press the **Start/Stop** button. 

NOTE: In the event of a prolonged power failure during the cooking process, it is strongly recommended that you ensure the food is safe for consumption according to local health regulations.

Temperatures below 350°F (177°C) permit high speed fan and low speed fan operation. Temperatures at 350°F (177°C) or higher permit only high speed fan operation.

Operation

Steam Mode Chef Operating Tips



This mode will steam a full or partial load of a single product, or multiple products without transfer of flavors. When steaming multiple products, however, individual product cooking times must be taken into

consideration. The non-pressurized atmosphere of the Combitherm also provides the ability to open the door during the steam mode in order to monitor products more closely throughout the steaming process.

Steam

Perforated, 2-1/2" (65mm) deep pans are particularly suitable for use in this program mode. These pans will provide a shorter cooking time and will prevent product over-cooking at the bottom of the pan.

Separate ice-encrusted vegetables before steaming to ensure even cooking.

A variety of products can be steamed at the same time but attention must be paid to the different cooking times required for each food product.

NOTE: When cooking by probe, the probe tip must be inserted and positioned in the center of the food mass. For liquid or semi-liquid foods, suspend the probe in the center of the product and secure the probe wire to the edge of the container.

High Temp Steam

High temperature steaming is suitable for hearty, root-type vegetables such as potatoes, turnips, carrots, and cabbage.

High temperature steaming provides a cooking time which is approximately 10% shorter than the regular steam mode temperature of 212°F (100°C).

Low Temp Steam

The low temperature steam mode will function whenever the oven compartment temperature is below 212°F (100°C).

It will take longer to steam products using the low temperature steam mode.

Steaming sausages in low temperature steam prevents cracked or peeling skins.

Use low temperature steam for delicate foods such as shrimp, fish, seafood, crème caramel, and sous vide.

For best results, low temperature steam all delicate food items at a temperature of 210°F (99°C) or below.

Combination Mode Chef Operating Tips



The Combination mode injects the optimum amount of steam automatically. There is no need to select humidity levels. Foods do not dry out. Flavors are retained with no transfer of flavors when mixing product loads.

Due to automatic steam adjustment, the door can be opened at any time during a cooking operation. To avoid steam burns, use caution when opening the oven door.

CAUTION

Burn hazard. Hot cooking chamber generates steam which escapes when oven door is opened. To avoid steam burns, open oven door slowly and stand away from door opening.

The Combination mode is particularly efficient when used for baking, broiling, grilling, stewing, braising, and roasting.

When using the Combination mode, cooking temperatures can be reduced 10–20% below temperatures required for conventional cooking methods.

Convection Mode Chef Operating Tips



The Convection Mode can be used to roast or bake products needing very short cooking times, for high moisture products such as muffins, cakes, and cookies, or for browning the surface of the food.

The Convection mode works best with low moisture foods or for very moist foods requiring a drier finished product.

When using the Combination mode, cooking time will be reduced approximately 40% when cooking at the same temperature used for convection oven cooking. Approximately 50–60% less time is used when cooking at the same temperature used for a conventional oven.

Food browning in the Combitherm begins at a cooking temperature of approximately 250°F (120°C).

A higher cooking temperature results in darker browning but also results in greater product weight loss.

The Combination mode provides even browning without the necessity to turn the pans.

For more even cooking, do not cook in pans deeper than 4" (102mm).

For baking, preheat the Combitherm at a temperature of 325°F to 375°F (163°C to 191°C). Once preheated, reset the temperature as required.

A higher cooking temperature results in darker browning but also results in greater product weight loss.

NOTE: When cooking by probe, the probe tip must be inserted and positioned in the center of the food mass. For liquid or semi-liquid foods, suspend the probe in the center of the product and secure the probe wire to the edge of the container.

Options

CombiHood PLUS™ Ventless Hood Option

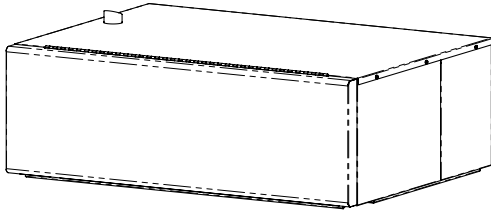

The CombiHood PLUS option is factory installed directly on the top of the Alto-Shaam Combitherm CTP or CTC series oven.

- Using EPA method 202 testing, grease laden vapors emitted by the Combi Ventless hood are 0.58 mg/m^3 – far less than U.L.’s established standard of 5 mg/m^3 .
- A high-powered fan captures all steam and fumes from the oven cavity into the hood intake and routes them out the back surface exhaust vent, trapping grease as the air moves through the filter system.
- As fumes and vapors are circulated through the hood, condensed steam drains from a drain at the rear of the hood.
- An activated charcoal filter cleans the air before venting it out the top of the hood.
- CombiHood PLUS™ performance is “smart”; engaging the fan during the last minute of the cook mode which provides quiet operation and consumes less power.

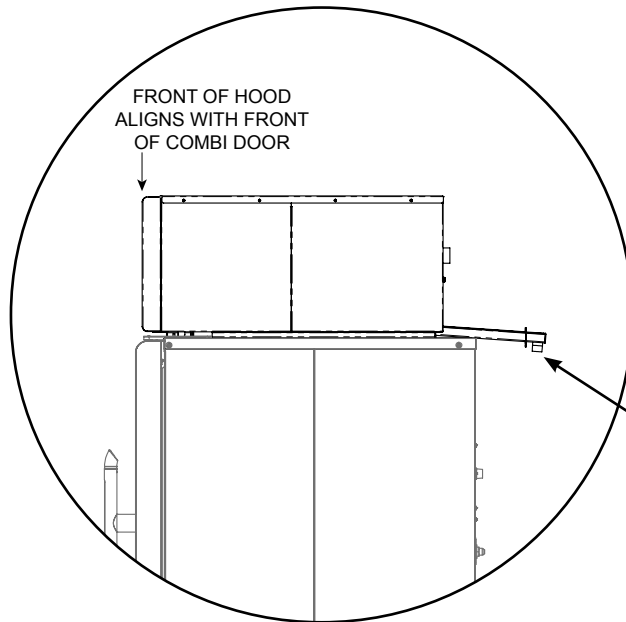

Condensate Drain

A condensate drain line to the floor drain must be installed. The 1/2" barbed connection is found at the back of the hood. The drain line must always be a positive gradient away from the Combitherm oven.

Test the drain for proper drainage and signs of leaking on a monthly basis.

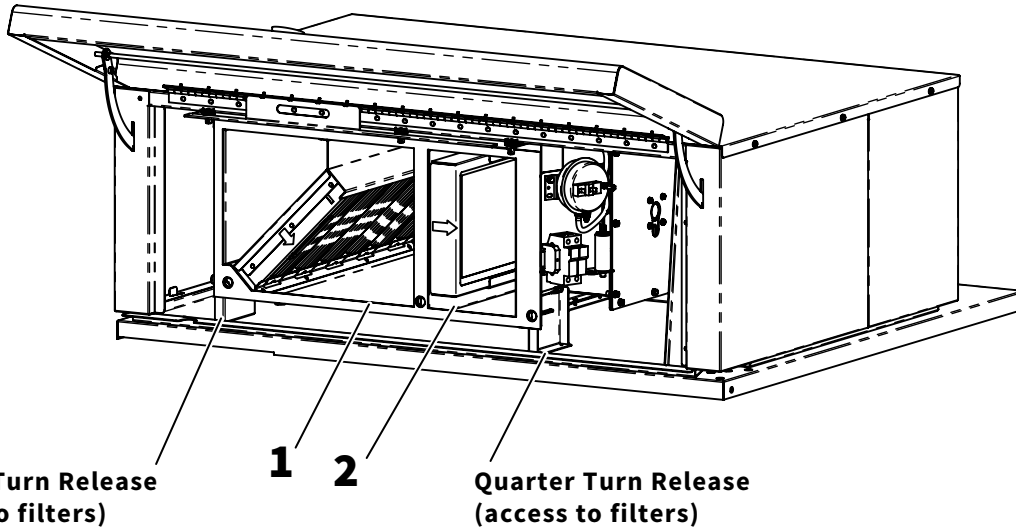
CombiHood PLUS™ Ventless Hood Option

1 CombiHood Plus Washable Grease Filter with metal housing (5017362)

Washing frequency should be based on oven usage with a maximum of two weeks between cleaning if the oven is used for non-grease laden products or steam applications only. Grease laden products require cleaning frequency of at least once a week.

Remove the grease filter by pulling it straight out of the housing. Place the filter in the dishwasher or wash separately by placing in hot, soapy water until all grease and particles have been removed. Rinse thoroughly. Allow the filter to air dry before reinstalling.

The air flow arrow on the filter casing should point toward the hood fan when the filter is reinstalled.

2 CombiHood Plus Charcoal Filter with paper housing, Class II (FI-25866)

CombiHood Plus Charcoal Filter with paper housing, Class I *required for New York City and Los Angeles* (FI-36620)

The charcoal filter should be inspected once a month for contaminants. Replacement must be made at a minimum of three month intervals – more often if heavy contaminants are visible or if the filter no longer controls odors.

To remove the filter, pull and slide out while holding the bottom housing. When replacing the filter, make certain the air flow arrow(s) point toward the hood fan, and that the filter is replaced in the three-sided metal frame provided with the hood.

NOTICE: A pressure switch is used to detect when the airflow through the charcoal filter is reduced by 25%, indicating a possible blockage. This will generate an E101 error message on the oven control display. The filters will need to be cleaned or replaced.

If the filters are not seated properly, an error code E102 will appear on the oven control display at the end of a cooking cycle.

Recipe Guidelines

Bakery Items

Food Item	Preheat Temp	Cooking Mode	Cook Temp	Time / Probe	Fan Speed
Bakery (retherm)	275°F (135°C)	Combi	275°F (135°C)	4 minutes	100%
Brownies	325°F (163°C)	Convection	325°F (163°C)	25 minutes	100%
Cinnamon rolls	350°F (177°C)	Combi	350°F (177°C)	8 minutes	100%
Cookies	325°F (163°C)	Convection	325°F (163°C)	12 minutes	100%
Croissants	340°F (171°C)	Combi	340°F (171°C)	9 minutes	100%
Danish pastry	340°F (171°C)	Combi	340°F (171°C)	11 minutes	100%
Dinner rolls	350°F (177°C)	Combi	350°F (177°C)	10 minutes	100%
French bread	385°F (196°C)	Combi	385°F (196°C)	1 minute	100%
		Convection	385°F (196°C)	15 minutes	
Fruit pie	340°F (171°C)	Convection	340°F (171°C)	60 minutes	100%
Muffins	340°F (171°C)	Convection	340°F (171°C)	20 minutes	50%
Par-baked bread - frozen	350°F (177°C)	Combi	350°F (196°C)	1 minute	50%
		Convection	350°F (177°C)	9 minutes	
Par-baked rolls	350°F (177°C)	Combi	350°F (177°C)	13 minutes	100%
Proofing	—	Steam	90°F (32°C)	30 minutes	100%
Puff pastry	375°F (191°C)	Combi	375°F (191°C)	1 minute	100%
		Convection	375°F (191°C)	16 minutes	
Sheet cake	340°F (171°C)	Convection	325°F (163°C)	20 minutes	100%

Convenience Product Items

Food Item	Preheat Temp	Cooking Mode	Cook Temp	Time / Probe	Fan Speed
Chicken wings	425°F (218°C)	Combi	400°F (204°C)	10 minutes	100%
Corn dogs - thawed	300°F (149°C)	Combi	300°F (149°C)	10 minutes	100%
Egg rolls	400°F (204°C)	Combi	375°F (191°C)	15 minutes	100%
Entrée (4 Lb frozen)	350°F (177°C)	Combi	350°F (177°C)	140-160 minutes	50%
French fries - full load	475°F (246°C)	Combi	375°F (191°C)	1 minute	100%
		Convection	375°F (191°C)	10 minutes	
Hamburger patties - frozen	375°F (191°C)	Combi	350°F (177°C)	12 minutes	100%
Hamburger patties - thawed	375°F (191°C)	Combi	350°F (177°C)	5 minutes	100%
Mini pizza 5" (127mm)	350°F (177°C)	Combi	350°F (177°C)	10 minutes	100%
Pizza - fresh	350°F (177°C)	Combi	350°F (177°C)	11 minutes	50%
Spring rolls - fresh or frozen	350°F (177°C)	Combi	350°F (177°C)	1 minute	100%
		Convection	350°F (177°C)	14 minutes	
Tater Tots®	425°F (218°C)	Combi	375°F (191°C)	10 minutes	100%

Recipe Guidelines

Fish & Seafood Items

Food Item	Preheat Temp	Cooking Mode	Cook Temp	Time / Probe	Fan Speed
Baked fish - fresh	450°F (232°C)	Combi	400°F (204°C)	10 minutes	100%
Lobster - whole	160°F (71°C)	Steam	195°F (91°C)	13 minutes	50%
Salmon filets	—	Steam	145°F (63°C)	7 minutes	50%
Salmon steaks	—	Steam	145°F (63°C)	8 minutes	100%
Shrimp - frozen	—	Steam	158°F (70°C)	12 minutes	50%

Meats

Food Item	Preheat Temp	Cooking Mode	Cook Temp	Time / Probe	Fan Speed
Bacon	318°F (159°C)	Combi	318°F (159°C)	1 minute	100%
		Convection	318°F (159°C)	15 minutes	
Beef - tenderloin	250°F (121°C)	Combi	250°F (121°C)	Probe option 125°F (52°C)	50%
Beef - tri tips	250°F (121°C)	Combi	250°F (121°C)	Probe option 125°F (52°C)	50%
Beef rounds - using probe	250°F (121°C)	Combi	250°F (121°C)	Probe option 125°F (52°C)	50%
Breakfast sausage links	350°F (177°C)	Combi	350°F (177°C)	8 minutes	100%
Burgers (school) - precooked and grilled	350°F (177°C)	Combi	350°F (177°C)	Frozen - 8 minutes Thawed - 4 minutes	100%
Hamburger patties - frozen	375°F (191°C)	Combi	350°F (177°C)	1 minute	100%
Meat loaf by core temp	325°F (163°C)	Combi	275°F (135°C)	Probe option 155°F (68°C)	100%
Pork - back ribs - raw	250°F (121°C)	Combi	250°F (121°C)	1 hour 15 minutes	100%
Pork - loin - by core temp	325°F (163°C)	Combi	300°F (149°C)	Probe option 150°F (66°C)	100%
Pork ribs reheat	400°F (204°C)	Combi	400°F (204°C)	7 minutes	100%
Sausage - fresh		Low Temp Steam	160°F (71°C)	15 minutes	50%

Miscellaneous Foods

Food Item	Preheat Temp	Cooking Mode	Cook Temp	Time / Probe	Fan Speed
Custard creme brûlée		Steam	190°F (88°C)	55 minutes	50%
Eggs - hardboiled	212°F (100°C)	Steam	212°F (100°C)	12 minutes	100%
Eggs - poaching pan	212°F (100°C)	Steam	212°F (100°C)	3 minutes	50%
Eggs - poaching pan (low steam)	—	Steam	170°F (77°C)	12 minutes	—
Eggs - scrambled in bag; shake at 18 minutes	212°F (100°C)	Steam	212°F (100°C)	25 minutes	100%
Eggs - scrambled in pan	212°F (100°C)	Steam	212°F (100°C)	15 minutes	100%
Eggs - sous vide	—	Steam	148°F (64°C)	60 minutes	50%
Pasta - linguine or spaghetti	212°F (100°C)	Steam	212°F (100°C)	20 minutes	100%
Rice	212°F (100°C)	Steam	212°F (100°C)	30 minutes	100%
Tamales	212°F (100°C)	Steam	212°F (100°C)	30 minutes	100%

Poultry

Food Item	Preheat Temp	Cooking Mode	Cook Temp	Time / Probe	Fan Speed
Chicken - oven fried pieces	450°F (232°C)	Combi	450°F (232°C)	2 minutes	100%
		Convection	450°F (232°C)	16 minutes	
Chicken - pre-cooked pieces - frozen	350°F (177°C)	Combi	350°F (177°C)	35 minutes	100%
Chicken - pre-cooked pieces - refrigerated	350°F (177°C)	Combi	350°F (177°C)	15 minutes	100%
Chicken - thawed whole	350°F (177°C)	Combi	350°F (177°C)	35 minutes	100%
Chicken - 8 piece cut up	375°F (191°C)	Combi	375°F (191°C)	30 minutes	100%
Grilled chicken breasts	550°F (288°C)	Combi	460°F (238°C)	6 minutes	100%

Recipe Guidelines

Vegetables

Food Item	Preheat Temp	Cooking Mode	Cook Temp	Time / Probe	Fan Speed
Asparagus - fresh	—	Steam	190°F (88°C)	3 minutes	50%
Broccoli, cauliflower, squash, zucchini - fresh	212°F (100°C)	Steam	212°F (100°C)	3 - 6 minutes	100%
Cabbage, green beans - fresh	212°F (100°C)	Steam	212°F (100°C)	8 - 10 minutes	100%
Carrots - fresh	225°F (107°C)	Steam	225°F (107°C)	10 minutes	100%
Corn-on-the-cob - fresh	212°F (100°C)	Steam	212°F (100°C)	14 minutes	100%
Frozen vegetables	212°F (100°C)	Steam	212°F (100°C)	8 minutes	100%
Potatoes, for mashed, full loaded	212°F (100°C)	Steam	212°F (100°C)	30 minutes	100%
Potatoes, for mashed, small loaded	212°F (100°C)	Steam	212°F (100°C)	30 minutes	100%
Potatoes, red or salad	212°F (100°C)	Steam	212°F (100°C)	30 minutes	100%
Potatoes, roasted	400°F (204°C)	Combi	400°F (204°C)	18 minutes	100%

CombiClean® Cleaning Agents

! DANGER

ALWAYS wear rubber gloves when using CombiClean tablets or spray oven cleaner.

! DANGER

ALWAYS wear protective eye wear when using spray oven cleaner.

Danger

- May be harmful if swallowed.
- May be harmful in contact with skin. Always wear rubber gloves when handling.
- Causes severe skin burns and eye damage.
- Tablet will begin to dissolve onto skin if handled with damp or wet hands.
- May cause respiratory irritation.
- May cause drowsiness or dizziness.
- Harmful to aquatic life with long lasting effects. Do not mix with anything but water.
- Do not breathe dust, fumes, gas, mist, vapors, or spray. Wash face, hands, and any exposed skin thoroughly after handling. Wear protective gloves, protective clothing, eye protection, and face protection.
- Use only outdoors or in a well-ventilated area. Avoid release to the environment. Store in a locked and well ventilated place. Keep container tightly closed. Dispose of contents/container to an approved waste disposal plant.

First Aid

Immediately call a POISON CENTER or doctor/physician. Specific treatment (See section 4 on the SDS).

- **IF IN EYES:** Rinse cautiously with water for several minutes. Remove contact lenses, if present and easy to do. Continue rinsing. Immediately call a POISON CENTER or doctor/physician.
- **IF ON SKIN (or hair):** Remove/Take off immediately all contaminated clothing. Rinse skin with water/shower. Wash contaminated clothing before reuse.
- **IF INHALED:** Move victim to fresh air and keep at rest in a position comfortable for breathing. Immediately call a POISON CENTER or doctor/physician if you feel unwell.
- **IF SWALLOWED:** Rinse mouth. DO NOT induce vomiting. Drink 2-3 glasses of water or milk. Immediately call a POISON CENTER or doctor/physician.

Cleaning and Preventative Maintenance

Daily Inspection

Unit Information

Business Name: _____

Serial Number: _____

Model Number: _____

Daily Inspection Start Date: _____

Daily Inspection Checklist

	Monday	Tuesday	Wednesday	Thursday	Friday	Saturday	Sunday
Inspect and clean:							
Product probe (thermometer)							
Door gasket (inner door seal)							
Inner door glass							
Front drip tray							
Screen and overlay (inspect for cracks, peeling, moisture, etc.)							
Execute automatic wash cycle (with approved cleaning chemical ONLY)							
Employee initials							

Component Malfunction and Replacement

List details of the failure(s) next to the day they occurred. Leave blank if components are working properly.	
Monday	
Tuesday	
Wednesday	
Thursday	
Friday	
Saturday	
Sunday	

Weekly Inspection

Unit Information

Business Name: _____

Serial Number: _____

Model Number: _____

Weekly Inspection Start Date: _____

Weekly Inspection Checklist

Inspect - Oven cavity lamp	
Inspect - Oven cavity for signs of grease/carbon buildup	
Inspect - Loosen thumb screws to inspect behind the fan panel inside the oven cavity for signs of grease/carbon buildup	
Inspect - Loosen thumb screws to inspect behind the fan panel inside the oven cavity for signs of scale buildup	
G Inspect - The heat exchanger for any signs of major deformation. If yes, immediately remove from service and take corrective action steps.	
G Inspect - The heat exchanger for any loose/disconnected pipes or flanges. If yes, immediately remove from service and take corrective action steps.	
E Inspect - Convection elements for signs of cracking, deformation, or damage	
Clean ventless hood grease filters	
Employee initials	

G Gas units only

E Electric units only

Component Malfunction and Replacement

List details of the failure(s) next to the day they occurred. Leave blank if components are working properly.	
Week 1	
Week 2	
Week 3	
Week 4	

Cleaning and Preventative Maintenance

Monthly Inspection

Unit Information

Business Name: _____

Serial Number: _____

Model Number: _____

Monthly Inspection Start Date: _____

Monthly Inspection Checklist

Inspect/Test - Proper draining of the oven cavity	
Inspect - All drain lines for leaks or clogs	
EB Descale the steam generator	
Inspect - Oven cavity for any signs of scale buildup	
Descale the oven interior	
Inspect ventless hood paper filter (replace as needed)	
Test ventless hood drain for proper drainage and signs of leaking	
Employee initials	

EB Electric boiler units only

Component Malfunction & Replacement

Summarize any component failure(s) that may have occurred during this month.

Yearly Inspection

Unit Information

Business Name: _____

Serial Number: _____

Model Number: _____

12-Month Inspection Start Date: _____

12-Month Inspection Checklist

Replace - Steam bypass hose	
Inspect - Cleaning pump hose	
Inspect/Test - Proper draining of the oven cavity	
Inspect - All drain lines for leaks or clogs	
Inspect - All solenoid hoses (both ends)	
Inspect - Upper browning valve hose	
Inspect - Low pressure relief valve & hose	
E Inspect - Convection element seal (from the electrical compartment)	
G Inspect - Gas heat exchanger seal (from the electrical compartment)	
Inspect - N6 oven temperature probe seal	
EB Descale the steam generator	
EB Remove & Inspect - Steam generator elements	
Inspect - Hand shower hose	
Inspect - Hand shower handle	
Inspect - Product probe	
Inspect - Water injection tube	
Inspect - Oven cavity for any signs of scale buildup	
Inspect - Oven cavity lamp	
Inspect - Oven cavity for signs of grease/carbon buildup	
Inspect - Behind the fan panel inside the oven cavity for signs of grease/carbon buildup	
Inspect - Behind the fan panel inside the oven cavity for signs of scale buildup	

EB Electric boiler units only **G** Gas units only **E** Electric units only

Cleaning and Preventative Maintenance

Unit Information

Business Name: _____

Serial Number: _____

Model Number: _____

12-Month Inspection Start Date: _____

12-Month Inspection Checklist

G	Inspect - The heat exchanger for any signs of major deformation. If yes, immediately remove from service and take corrective action steps.	
G	Inspect - The heat exchanger for any loose/disconnected pipes or flanges. If yes, immediately remove from service and take corrective action steps.	
G	Inspect and Ensure - Exhaust pipes are exiting the oven cavity	
G	Inspect - Heat exchanger flange gasket (replace as needed)	
G	Inspect and Tighten - Heat exchanger flange bolts	
G	Inspect and Tighten - Heat exchanger burner flange hardware & gasket (replace as needed)	
G	Inspect and Tighten - Heat exchanger igniter flange hardware & gasket (replace as needed)	
G	Inspect - Heat exchanger exhaust pipes (ensure they are exiting out past the oven cavity ceiling flange) - ESG models only	
G	Inspect - Oven cavity ceiling flange & flange gasket - ESG models only	
G	Tighten - Burner flange bolts	
G	Tighten - Igniter flange bolts	
	Inspect - Heat exchanger weep holes to ensure they are free of obstructions (if the hole is obstructed, immediately remove oven from service and replace the heat exchanger) - Not applicable to CTP/CTC models	
E	Inspect - Convection elements for signs of cracking, deformation, or damage	
	Replace - Oven lamp cover(s) & gasket(s)	
	Descale the oven interior	
	Inspect - Upper and lower door hinges and pins	
	Inspect - Door gasket (replace as needed)	
	Inspect - Door upper and lower hinges (replace as needed)	
	Wipe the inner door glass	
	Inspect - Front drip tray (clean as needed)	
	Inspect - Front drip tray hose	
	Inspect - Control overlay	
	Inspect and Tighten - All electrical connections	
	Inspect and Tighten - All cooling fans for proper operation	

EB Electric boiler units only **G** Gas units only **E** Electric units only

Cleaning and Preventative Maintenance

Unit Information

Business Name: _____

Serial Number: _____

Model Number: _____

12-Month Inspection Start Date: _____

12-Month Inspection Checklist

Inspect and Tighten - Door hinges and lower hinge pin bolt	
Inspect and Tighten - Door handle	
If there is a smoker, inspect the smoke element for visual signs of deformation, cracks or breaks (replace as needed)	
Review - Error code history	
Note the software version (update if not current)	
Record - Water pressure (static & dynamic)	
Record - Line voltage across all lines	
Record - Line voltage to ground on each line	
Record - Amperage across all three legs (when heating)	
Function test all components (list components)	
For ovens shipped to New Zealand or Australia, inspect the backflow preventer check valve per AS/NZ3500.1 and AS/NZ3500.2	

Component Failure and Replacement

Summarize any component failure(s) that may have occurred during this month.

Customer Signature: _____

Technician Signature: _____

Cleaning and Preventative Maintenance

Preventative Maintenance

In addition to routine cleaning and maintenance procedures, there are several additional steps to be taken to maintain sanitation and keep the oven running efficiently. Refer to the inspection checklists for a comprehensive approach to longevity and equipment efficiency. These additional safeguards will help prevent down time and costly repairs.

Do not dispose of grease, fat, or solid waste down the oven drain.

Fats and solids will eventually coagulate in the drain system, causing blockage. Consequently, water will back up into the condenser and interior oven compartment, resulting in an oven that is inoperable.

Verify the drain screen is always in place. Remove any solid waste from the oven bottom and drain screen before it enters the drain system.

Routine removal of solids from the drain screen will help prevent blockage.

Use the authorized Combitherm oven cleaner only.

The use of unauthorized cleaning agents may discolor or harm the interior surfaces of the oven.

To prolong the life of the door gasket, clean this item daily.

Acids and related compounds found in fat, particularly chicken fat, will weaken the composition of the gasket unless cleaned on a daily basis. Wipe with a hot, soapy cloth.

To additionally protect gasket life, allow oven door to remain slightly open at the end of the production day.

An open door will relieve the pressure on the door gasket.

Routinely clean door hinges.

Open oven door to relieve tension. Clean all parts of the hinge.

On a monthly basis, decalcify or descale the oven.

Place seven (7) ounces of Scale Free Cleaner CE-27889 in the drain. Run a heavy-duty cleaning cycle. After the cleaning cycle is complete, use the hand shower to spray the oven interior. Swing open the interior fan guard and spray the area behind the panel. Direct a stream of water down the interior drain cover to thoroughly rinse cleaner from the oven. After the oven interior has been sprayed, run a rinse cleaning cycle.

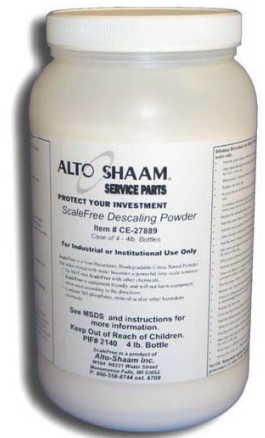

WARNING



To prevent serious personal injury, death, or property damage:

Do not steam clean, hose down or flood the interior or exterior with water or liquid solution of any kind. **Do not** use water jet to clean. Failure to observe this precaution will void the warranty.

Sweep Gasket Installation (10-10 or 10-20 models only)

1. Position the sweep gasket as shown in the illustration below, noting the position of the top groove ①, door side ②, and bottom groove ③.

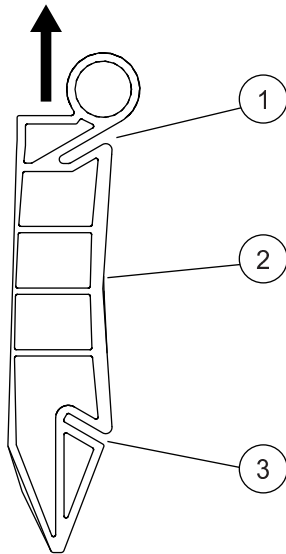

2. Grasp the sweep gasket with your right hand, and open the bottom groove with your index finger.

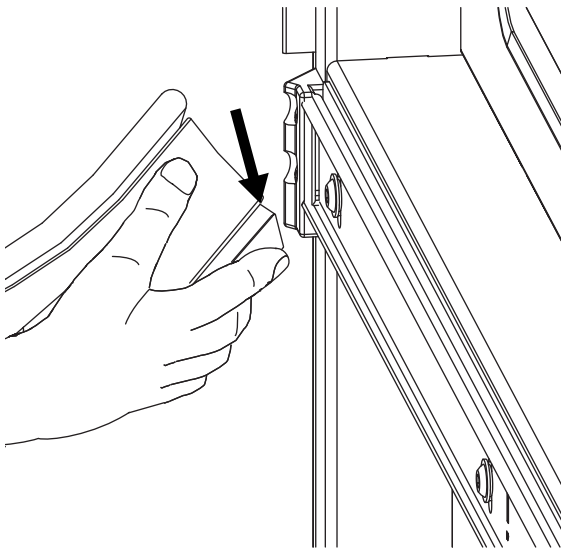

3. Starting at the left end, press the bottom groove of the sweep gasket over the bottom lip of the gasket retention channel.

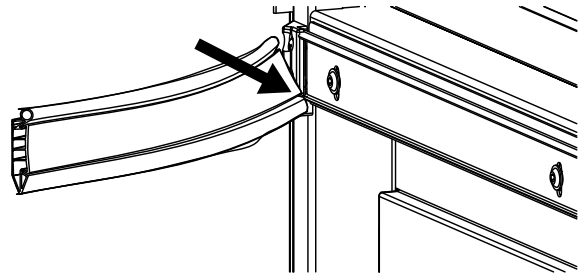

4. Bend the sweep gasket to open up the bottom groove. Continue to press the bottom groove over the bottom lip of the gasket retention channel.

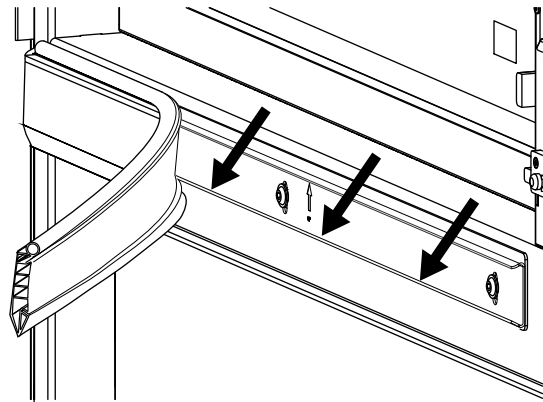

Page Title

Sweep Gasket Installation (10-10 or 10-20 models only) Continued from previous page

5. Press the top groove of the sweep gasket onto the top lip of the gasket retention channel.

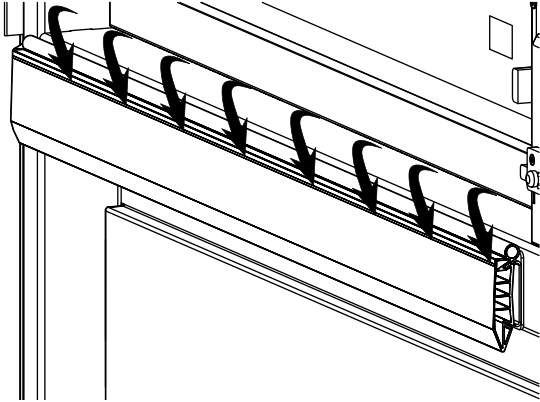

7. Push the ends of the retention strap into the block.

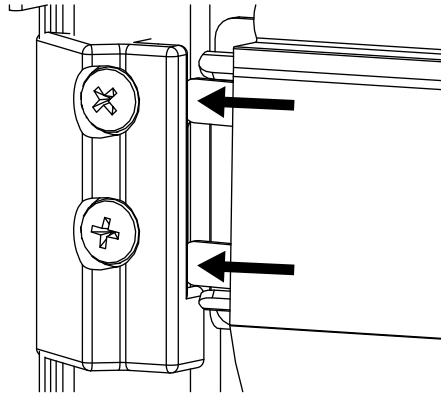

6. Insert the retention strap into the sweep gasket, and push it all the way through until fully seated.

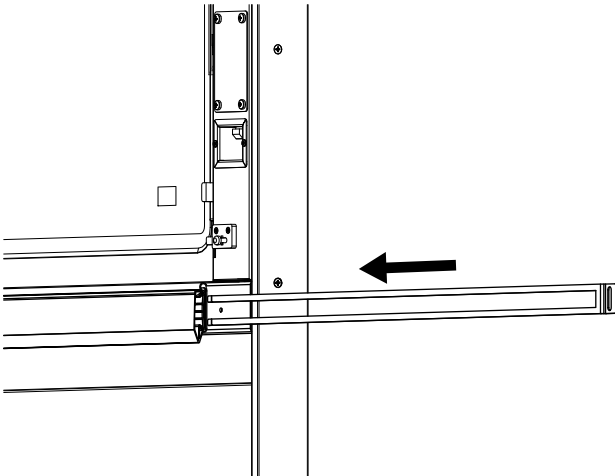

8. Install the retaining strap screw to secure the retaining strap in place.

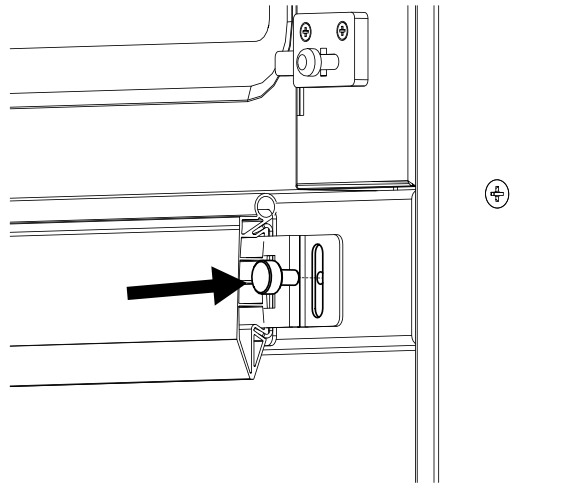

Protecting Stainless Steel Surfaces



It is important to guard against corrosion in the care of stainless steel surfaces. Harsh, corrosive, or inappropriate chemicals can completely destroy the protective surface layer of stainless steel. Abrasive pads, steel wool, or metal implements will abrade

surfaces causing damage to this protective coating and will eventually result in areas of corrosion. Even water, particularly hard water that contains high to moderate concentrations of chloride, will cause oxidation and pitting that result in rust and corrosion. In addition, many acidic foods spilled and left to remain on metal surfaces are contributing factors that will corrode surfaces.

Proper cleaning agents, materials, and methods are vital to maintaining the appearance and life of this appliance. Spilled foods should be removed and the area wiped as soon as possible but at the very least, a minimum of once per day. Always thoroughly rinse surfaces after using a cleaning agent and wipe standing water as quickly as possible after rinsing.

Cleaning Agents

Use non-abrasive cleaning products designed for use on stainless steel surfaces. Cleaning agents must be chloride-free compounds and must not contain quaternary salts. Never use hydrochloric acid (muriatic acid) on stainless steel surfaces. Failure to observe this precaution will void the warranty. Always use the proper cleaning agent at the manufacturer's recommended strength. Contact your local cleaning supplier for product recommendations.

Cleaning Materials

Cleaning can usually be accomplished with the proper cleaning agent and a soft, clean cloth. When more aggressive methods are needed, use a non-abrasive scouring pad on difficult areas and make certain to scrub with the visible grain of surface metal to avoid surface scratches. Never use wire brushes, metal scouring pads, or scrapers to remove food residue. Failure to observe this precaution will void the warranty.

NOTICE



To protect stainless steel surfaces, completely avoid the use of abrasive cleaning compounds, chloride based cleaners, or cleaners containing quaternary salts. **Never** use hydrochloric acid (muriatic acid) on stainless steel. **Never** use wire brushes, metal scouring pads or scrapers.

! WARNING



To prevent **serious personal injury, death, or property damage:**

The appliance must be cleaned thoroughly to avoid deposits of grease and or food residue inside the appliance that may catch fire. If fat deposits and/or food waste inside the appliance ignite, shut down the appliance immediately and keep the appliance door closed to extinguish the fire. If further extinguishing is required, disconnect the appliance from the main power and use a fire extinguisher (do not use water to extinguish a grease fire!). Failure to clean the appliance properly invalidates the warranty and relieves Alto-Shaam of all liability.

Cleaning and Preventative Maintenance

WARNING



To prevent serious personal injury, death, or property damage:

Do not steam clean, hose down or flood the interior or exterior with water or liquid solution of any kind. **Do not** use water jet to clean. Failure to observe this precaution will void the warranty.

Cleaning the Oven

Cleaning is to be performed at the end of the production day or between production shifts.

1. Allow the oven to cool.
2. Remove the optional grill grate from the oven interior and wash separately in hot, soapy water to preserve the special non-stick coating.
3. Release the hinged inner glass on the CoolTouch3™ triple pane window door. Clean both sides of each pane of glass with a window cleaner or vinegar.
4. Wipe the control panel and door handle thoroughly.
5. Use the optional Drip Tray Clean-out Brush [5021126] to remove grease and food debris from the drip tray drain line. Insert brush first, and push into the drip tray drain opening until 6" (152mm) or less remains of the wire handle. Remove the brush and repeat as necessary.
6. Clean the door gasket. Wipe the gasket and crevices with a clean cloth soaked in non-abrasive cleaning agent. Wipe again with a cloth and clean rinse water. Certain conditions will accelerate the wear of the door seal and routine cleaning will prolong the life of the door gasket:
 - continuous operation at high cooking temperatures
 - use of low humidity levels
 - production with predominantly high-fat foods

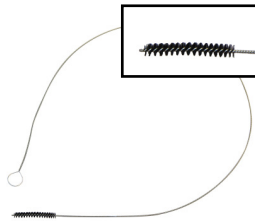

Do not attempt to remove the gasket or place in the dishwasher.

7. To help maintain the protective film coating on polished stainless steel, clean the exterior of the appliance with a cleaner recommended for stainless steel surfaces. Spray the cleaning agent on a clean lint-free cloth and wipe with the grain of the stainless steel.

Cleaning the Probe

1. Remove all food debris from the probe between loads and at the end of each production shift. Wipe the entire probe, probe cable assembly, probe prongs, and probe holding bracket with a clean cloth and warm detergent solution.
2. Remove detergent by wiping the probe, cable, probe prongs, and bracket with a cloth and clean rinse water.
3. Wipe the probe and probe bracket with a disposable alcohol pad or sanitizing solution recommended for food contact surfaces.
4. Allow the probe, probe prongs, and cable to air dry in the probe holding bracket.
5. Wipe the probe with a disposable alcohol pad prior to inserting into a new food product.

Cleaning the Roll-In Cart/Food Trolley

1. Move the food trolley to a cart wash area. Clean the food trolley with a mild, non-abrasive cleaning detergent and warm water.
2. Hand wipe all framing, slides, drip pan, and base. Thoroughly clean debris from the casters. A spray hose can be used to clean the food trolley.
3. Remove detergent solution with warm water.
4. Wipe or spray with a sanitizing solution designed for use on metal and vinyl food contact surfaces.
5. Allow the food trolley to air dry.

As an alternative, food trolleys can be cleaned while inside the oven. Allow the trolley to remain in the oven through the heavy-duty cleaning cycle, followed by steps 2 through 5.

Monthly Cleaning

- spray head
- water intake filters
- drain pipe
- decalcify (descale) oven

Cleaning Process

One (1) heavy-duty cleaning cycle (2 hours 5 minutes) is offered. CombiClean® 18-gram CombiTabs™ (CE-36354), or Combitherm Liquid Spray Cleaner (CE-24750) may be used. Side racks and shelves may remain inside oven during cleaning. Remove the optional Grill Grate and solid wastes from the bottom of the oven and the drain screen to prevent blockage.

NOTICE: If a power outage occurs during any portion of the cleaning cycle, the oven will begin a six (6) minute forced-rinse cycle. Cook temperature display area will display "RIN". Cook time display area will display "-.--"

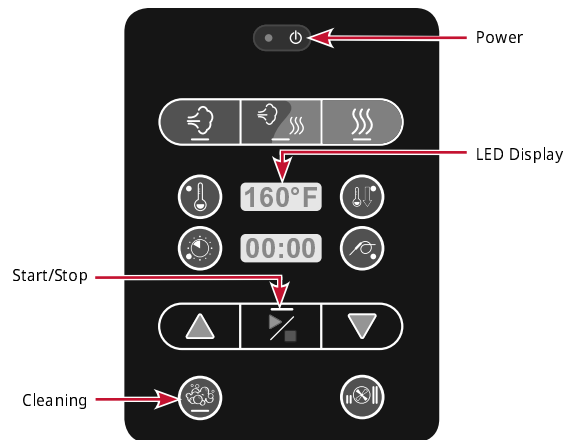

1. Press the **Cleaning** button. 

If the oven is too hot to proceed, "dOOr" will display on the LED screen. Open the oven door and allow the oven to cool below 150°F (66°C). When the oven is finished cooling, begin the cleaning procedure again.

2. The LED screen displays "CLn4". The "4" refers to the number of cleaning tablets to be inserted in to the cavity drain.

3. Wear rubber gloves to remove the interior drain-cover screen.

4. Tear open or cut open the plastic wrap surrounding the cleaning tablets.

5. Remove the tablets from the packaging. Discard the packaging. Insert the appropriate number of CombiClean® CombiTabs™ directly into the oven cavity drain, or spray CombiClean liquid cleaner inside the oven.

6. The number of tablets to be used can be increased depending upon how dirty the interior is.

7. Close the oven door and press the **Start/Stop** button. 

After the cleaning cycle is complete, leave the appliance door open approximately 2" (50mm) to allow the appliance to air dry.

US

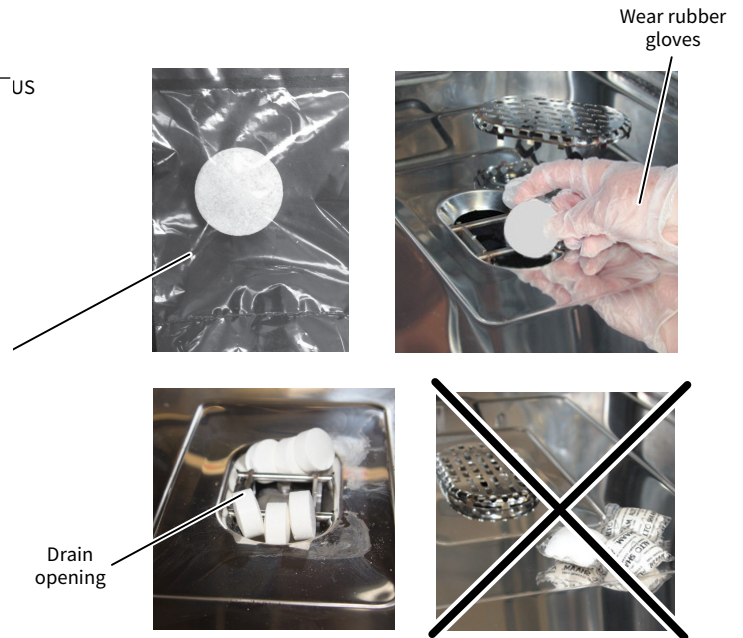

NOTICE: All tablets should be placed inside the drain as best as possible and drain screen re-installed before starting the cleaning cycle. Tablets placed on top of the drain cover or placed on the bottom of the oven will not dissolve properly and will cause the oven interior to deteriorate.

Troubleshooting

Error Codes

ALWAYS check the circuit breaker is turned “ON” and your unit is receiving power BEFORE calling your Authorized Alto-Shaam Service Agent.

NOTICE

This section is provided for the assistance of qualified and trained service technicians only and is not intended for use by untrained or unauthorized service personnel. Do not attempt to repair or service the oven beyond this point. Contact Alto-Shaam for the nearest authorized service agent. Repairs made by any other service agents without prior authorization by Alto-Shaam will void the warranty.

When the oven malfunctions, an error code will appear in the display.

 **Press the Start icon to acknowledge the error.**

When the oven error notification has been acknowledged, the Combitherm will attempt to return to normal operation.

Error Code	Error Call Out in Display	Description of Error	Possible Cause(s)
E01	Low Water Boiler	Upper water level probe B1 is not satisfied within 5 minutes, after water solenoid valve Y1 is activated.	<ul style="list-style-type: none"> – Water supply is shut off. – Low water pressure. – Boiler drain cap is missing. – Boiler drain pump is defective. – Drain pump elbow leaking. – Water level probe has calcium build up. – Double water solenoid valve is defective (Y1). – Relay board, high voltage is defective.
E02	Control Temperature High	Low voltage relay board temperature higher than 176°F (80°C).	<ul style="list-style-type: none"> – Check wiring to all components listed below. – Cooling fan on relay board assembly is defective. – Cooling fan on display board assembly is defective. – Main cooling fan is defective. – Cooling fan on motor drive is defective.
E03	Fan Motor Error	Fan motor does not spin after 60 seconds, detected by the Hall Sensor. Error 03 does not appear if error E53 is detected first.	<ul style="list-style-type: none"> – Check wiring to all components listed below. – If LED on motor control flashes, see error codes for motor control. – Motor or fan wheel locked. – Hall sensor does not detect motor rotation. – Motor Thermo Temperature protection. – Fan wheel damaged.
E04	Lower Fan Motor Error	Lower Fan motor does not spin after 60 seconds, detected by the Hall Sensor. Error 04 does not appear if error E54 is detected first.	<ul style="list-style-type: none"> – Check wiring to all components mentioned below. – If LED on motor control flashes, see error codes for motor control. – Motor or fan wheel locked. – Hall sensor does not detect motor rotation. – Motor Thermo Temperature protection. – Fan wheel damaged.
E05	VFD Comm Failure	When VFD does not respond to a query on the CAN interface.	<ul style="list-style-type: none"> – Loss of power to VFD. – VFD malfunction. – CAN cable disconnected. – CAN address not correct on VFD.

Continued on next page

Error Codes

Error Code	Error Call Out in Display	Description of Error	Possible Cause(s)
E06	Lower VFD Comm Failure	When VFD does not respond to a query on the CAN interface.	<ul style="list-style-type: none"> – Loss of power to VFD. – VFD malfunction. – CAN cable disconnected. – CAN address not correct on VFD.
E07	Error Received from VFD	When VFD is flashing the green light	– Refer to VFD error code list and match to number of blinks on the green LED of VFD.
E08	Error Received from Lower VFD	When VFD is flashing the green light	– Refer to VFD error code list and match to number of blinks on the green LED of VFD.
E11	Convection Temperature High	<p>In Combination program, cavity temperature N6 is measuring in excess of 572°F (300°C) for a minimum of 25 seconds</p> <p>In Convection program, cavity temperature N6 is measuring in excess of 572°F (300°C) for a minimum of 25 seconds</p>	<ul style="list-style-type: none"> – Check wiring to all components mentioned below. – Steam element contactor locked/on. – N6 oven cavity temperature probe is defective. – N6 oven cavity temperature probe wires connected backwards – Relay board, high voltage, defective.
E13	Boiler Temperature High	Boiler temperature is more than 248°F (120°C) for more than 25 seconds, detected by B4 Probe	<ul style="list-style-type: none"> – Calcium build up in boiler – Check wiring to all components mentioned below. – Steam element contactor locked/on. – B4 boiler temperature probe is defective. – B4 probe wires connected backwards – Water level probe has calcium build up.
E15	Condensor Temperature High	Condensor water temperature is more than 212°F (100°C) for more than 180 seconds, detected by B3 probe	<ul style="list-style-type: none"> – Water supply is shut off. – Check wiring to all components mentioned below. – B3 condensor temperature probe is defective. – B3 condensor probe wires connected backwards – Single water solenoid valve defective (Y2). – Relay board, high voltage, defective.
E20	B11 Core Temperature Probe Single Point Fault	Single point core temperature probe defective or disconnected	<ul style="list-style-type: none"> – Clean probe receptacle pins with sand paper. – B11 Single Point Core Temperature probe with quick connect defective. – B11 Single Point Core Temperature probe wires with quick connect disconnected. – B11 Single Point Core Temperature probe receptacle defective. – B11 Single Point Core Temperature probe receptacle wires disconnected.
E21	N6 Cavity Probe Fault	Cavity temperature probe defective or disconnected	<ul style="list-style-type: none"> – N6 oven cavity temperature probe defective. – N6 oven cavity temperature probe wires.
E22	B10 Core Temperature Probe Multi-point Fault	Multipoint core temperature probe defective or disconnected	<ul style="list-style-type: none"> – B10 multipoint core temperature probe defective. – B10 multipoint core temperature probe wires disconnected.
E23	B4 Boiler Probe Fault	Boiler temperature probe defective or disconnected	<ul style="list-style-type: none"> – B4 boiler temperature probe defective. – B4 probe wires connected backwards.
E24	B5 Bypass Probe Fault	Bypass steam temperature probe defective or disconnected	<ul style="list-style-type: none"> – B5 bypass steam temperature probe defective. – B5 bypass steam temperature probe wires connected backwards.
E25	B3 Condensor Probe Fault	Condensor water temperature probe defective or disconnected.	<ul style="list-style-type: none"> – B3 condensor temperature probe defective. – B3 condensor probe wires connected backwards.
E26	B10 - Point 1 - Core Temperature Probe Multipoint Fault	Multipoint core temperature probe defective or disconnected.	<ul style="list-style-type: none"> – B10 Multipoint Core Temperature probe defective. – B10 Multipoint Core Temperature probe wires disconnected.
E27	B10 - Point 2 - Core Temperature Probe Multipoint Fault	Multipoint core temperature probe defective or disconnected.	<ul style="list-style-type: none"> – B10 Multipoint Core Temperature probe defective. – B10 Multipoint Core Temperature probe wires disconnected.

Continued on next page

Troubleshooting

Error Codes

Error Code	Error Call Out in Display	Description of Error	Possible Cause(s)
E28	B10 - Point 3 - Core Temperature Probe Multipoint Fault	Multipoint core temperature probe defective or disconnected.	<ul style="list-style-type: none"> — B10 Multipoint Core Temperature probe defective. — B10 Multipoint Core Temperature probe wires disconnected.
E29	B10 - Point 4 - Core Temperature Probe Multipoint Fault	Multipoint core temperature probe defective or disconnected.	<ul style="list-style-type: none"> — B10 Multipoint Core Temperature probe defective. — B10 Multipoint Core Temperature probe wires disconnected.
E34	Steam Generator Drain Pump Fault	If water level does not drop below lower water level probe after three minutes when steam generator drain pump is activated in cleaning program.	<ul style="list-style-type: none"> — Calcium build up in steam generator drain pump. — Boiler drain pump defective. — Relay board, high voltage, defective. — Water level probe defective.
E36	Steam Temperature High	<p>In Steam program, cavity temperature N6 is measuring in excess of 395°F (200°C) for more than 60 seconds.</p> <p>In Combination program, cavity temperature N6 is measuring in excess of 520°F (270°C), for more than 60 seconds.</p> <p>In Retherm program, cavity temperature N6 is measuring in excess of 395°F (200°C), for more than 60 seconds.</p> <p>In Cleaning program, cavity temperature N6 is measuring in excess of 395°F (200°C), for more than 60 seconds.</p>	<ul style="list-style-type: none"> — Water supply is shut off. — Low water pressure. — Water injection pipe, calcium build up. — Water flow valve defect or calcium build up. — Double water solenoid valve defective (Y1). — Relay board, high voltage, defective.
E40	B3 Fault	B3 probe shorted to ground	— Defective or miswired probe.
E41	B4 Fault	B4 probe shorted to ground	— Defective or miswired probe.
E42	B5 Fault	B5 probe shorted to ground	— Defective or miswired probe.
E43	N6 Fault	N6 probe shorted to ground	— Defective or miswired probe.
E44	N8 Fault	N8 probe shorted to ground	— Defective or miswired probe.
E45	B10 Fault	B10 probe shorted to ground	— Defective or miswired probe.
E46	B10 - Point 1 Fault	B10 probe shorted to ground	— Defective or miswired probe.
E47	B10 - Point 2 Fault	B10 probe shorted to ground	— Defective or miswired probe.
E48	B10 - Point 3 Fault	B10 probe shorted to ground	— Defective or miswired probe.
E49	B10 - Point 4 Fault	B10 probe shorted to ground	— Defective or miswired probe.
E51	No Water In Boiler	Lower water level probe B2 is not satisfied within 5 minutes, after water solenoid valve Y1 is activated	<ul style="list-style-type: none"> — Water supply is shut off. — Low water pressure. — Boiler drain cap missing. — Boiler drain pump defective. — Drain pump elbow leaking. — Water level probe has calcium build up. — Double water solenoid valve defective (Y1). — Relay board, high voltage, defective.
E53	Fan Motor High Temperatures	Fan motor does not spin, result in over-heating, detected by motor coil safety thermo element. Temperature more than 320°F (160°C).	<ul style="list-style-type: none"> — Motor high limit open or wired incorrectly. — If LED on motor control flashes, see error codes for motor control. — Motor or fan wheel locked. — Fan wheel damaged.
E54	Lower Fan Motor High Temperature	Lower fan motor does not spin, result in over-heating, detected by motor coil safety thermo element. Temperature more than 320°F (160°C).	<ul style="list-style-type: none"> — Motor high limit open or wired incorrectly. — If LED on motor control flashes, see error codes for motor control. — Motor or fan wheel locked. — Fan wheel damaged.

Continued on next page

Error Codes

Error Code	Error Call Out in Display	Description of Error	Possible Cause(s)
E55	Vent Not Open (Lower vent on dual vent system)	60 seconds after the venting motor is activated the vent motor safety switch did not open.	<ul style="list-style-type: none"> – Alignment issue between motor cam and vent motor safety switch (micro switch). – Faulty vent valve (motor). – Faulty vent valve safety switch (micro switch).
E56	Vent 2 Not Open (Upper vent on dual vent system)	60 seconds after the venting motor is activated the vent motor safety switch did not open.	<ul style="list-style-type: none"> – Alignment issue between motor cam and vent motor safety switch (micro switch). – Faulty vent valve (motor). – Faulty vent valve safety switch (micro switch).
E57	No Rinse Water	Flow switch for solenoid valve Y4 does not detect any water flow for a minimum of 60 seconds.	<ul style="list-style-type: none"> – Water supply is shut off. – Low water pressure. – Flow switch is dirty or defective. – Double water solenoid valve defective (Y3). – Relay board, high voltage, defective.
E88	Lower Gas Ignition Failure NOTE: If after 2 attempts to clear this error, the error appears a third time, remove the oven from service and immediately contact an Alto-Shaam authorized service provider.	Reset output from Ignition Module is ON	<ul style="list-style-type: none"> – Hot surface ignitor not functioning. – No gas supply. – Flame sensor not functioning. – Faulty ignition control.
E89	Upper Gas Ignition Failure NOTE: If after 2 attempts to clear this error, the error appears a third time, remove the oven from service and immediately contact an Alto-Shaam authorized service provider.	Reset output from Ignition Module is ON	<ul style="list-style-type: none"> – Hot surface ignitor not functioning. – No gas supply. – Flame sensor not functioning. – Faulty ignition control.
E90	Lower Gas Combustion Blower Not at Speed	Speed is too slow.	<ul style="list-style-type: none"> – Power supply cable is not connected to blower motor. – Speed control cable is not connected to blower motor. – Blower motor is blocked, rotation is impeded, or motor is faulty. – Faulty control board.
E91	Upper Gas Blower Not at Speed	Speed is too slow.	<ul style="list-style-type: none"> – Power supply cable is not connected to blower motor – Speed control cable is not connected to blower motor – Blower motor is blocked, rotation is impeded, or motor is faulty – Faulty control board
E92	Communication Error CB does not properly respond	Twelve (12) instances of no-response from the relay board (CB) to the display board (IB).	<ul style="list-style-type: none"> – Check CAN cable connections. – CAN cable defective. – Relay board, low voltage, connector defective. – Display board connector defective.
E93	Interface Board (IB) and Control Board (CB) are in different states	The IB is in a different running state than the CB for more than 20 seconds.	<ul style="list-style-type: none"> – Check CAN cable connections. – CAN cable defective. – Relay board, low voltage, connector defective. – Display board connector defective.
E94	Communication Error, TO Interface Board	No signal transfer for more than 20 seconds between the Interface Board (IB) and the Control Board (CB).	<ul style="list-style-type: none"> – Check CAN cable connections. – CAN cable defective. – Relay board, low voltage, connector defective. – Display board connector defective.

Continued on next page

Troubleshooting

Error Codes

Error Code	Error Call Out in Display	Description of Error	Possible Cause(s)
E100	One or more maintenance reminder has timed out.	When any maintenance reminder has expired without action having been taken by the operator.	<ul style="list-style-type: none"> – Enter maintenance reminder screen and address the item that has timed out and reset
E101	Ventless Hood Fault - No Pressure	If the power switch or pressure switch is not closed.	<ul style="list-style-type: none"> – Check power switch is on. – Check vent motor is turning in the proper direction. – Pressure switch is miss wired or defective. – Filter(s) require cleaning or replacement
E102	Ventless Hood Fault — Filters Not Present	If the air filter switches are not closed.	<ul style="list-style-type: none"> – Check filters are installed and properly seated. – Check filter switches are not damaged, defective or dislodged.
E103	Option Board Doesn't Send Switch Setting	OB not communicating its switch settings to the CB.	<ul style="list-style-type: none"> – Check CAN cable connection between OB and CB. – Ensure CB dip switch is set to see an OB. – Incompatible OB and CB software (update software). – OB defective. – CB defective.
E104	Option Board Not Communicating	Option board is not communicating with CB.	<ul style="list-style-type: none"> – Check option board CAN connection at CB and OB. – Defective OB. – Defective CB.
E105	No or Low Water Pressure	Water pressure switch not activated.	<ul style="list-style-type: none"> – Water supply not connected. – Water supply is shut off. – Water supply to unit blocked or obstructed – Faulty or miswired pressure switch
E106	Boiler Drain Pump Fault	Hall effect or rotational sensor is not sending a signal to the relay board	<ul style="list-style-type: none"> – Drain pump motor not running or defective. – Hall effect sensor broken or incorrectly wired. – Motor improperly wired.
E108	Cooling Fan Failure	If the temperature on the control board (relay board) is greater than 140°F (60°C) and less than 176°F (80°C). (See error code E02)	<ul style="list-style-type: none"> – Cooling fan damaged. – Cooling fan blocked or blades have been kept from rotating. – Incoming air temperature exceeds 100°F (38°C). – Air inlet has become blocked.
E109	High Limit Switch NOTE: Any oven experiencing this error should be investigated by an authorized Alto-Shaam service provider.	The High Limit Switch input to the CB (N7) is "open"	<ul style="list-style-type: none"> – Unit has experienced an over heat condition. – Convection element contactors stuck closed. – Failed Y1 solenoid. – Obstruction between Y1 solenoid and injection pipe. – Improperly connected drain. – Condensate pan clean out not closed. – Improperly wired high limit switch at the switch or at the CB. – Defective high limit switch.

Continued on next page

Error Codes

Error Code	Error Call Out in Display	Description of Error	Possible Cause(s)
E200	The SD card has been detected to be larger than 2GB in size.	The SD card inserted is larger than 2GB in size.	– SD card is larger than 2GB in size. Contact service to order replacement SD card.
E210	VFD Under Voltage	VFD has detected an under-voltage situation.	– Possible VFD failure.
E211	VFD Over Voltage	VFD has detected an over-voltage situation.	– Possible VFD failure.
E212	VFD Overheating	VFD has detected an overheat situation.	– Unit has experienced an over heat condition. – Defective high limit switch. – Defective cooling fans. – Possible VFD failure.
E213	Motor Over Current	Motor over current detected.	– Blocked fan wheel. – Possible VFD failure.
E214	VFD Current Peak	VFD current peak detected.	– Possible VFD failure.
E215	VFD EEPROM Error	VFD EEPROM error detected.	– Possible VFD failure.
E216	VFD Over Current	VFD over current detected.	– Possible VFD failure.
E217	VFD Short Circuit	VFD Short Circuit detected.	– Possible VFD failure.
E218	VFD Voltage Error	VFD voltage does not correspond to jumper settings.	– VFD voltage jumper is not correct. – Possible VFD failure.
E220	Lower VFD Under Voltage	Lower VFD has detected an under-voltage situation.	– Possible Lower VFD failure.
E221	Lower VFD Over Voltage	Lower VFD has detected an over-voltage situation.	– Possible Lower VFD failure.
E222	Lower VFD Overheating	Lower VFD has detected an overheat situation.	– Unit has experienced an over heat condition. – Defective high limit switch. – Defective cooling fans. – Possible Lower VFD failure.
E223	Lower Motor Over Current	Lower Motor over current detected.	– Possible Lower VFD failure.
E224	Lower VFD Current Peak	Lower VFD current peak detected.	– Possible Lower VFD failure.
E225	Lower VFD EEPROM Error	Lower VFD EEPROM Error detected.	– Possible Lower VFD failure.
E226	Lower VFD Over Current	Lower VFD over current detected.	– Possible Lower VFD failure.
E227	Lower VFD Short Circuit	Lower VFD short circuit detected.	– Possible Lower VFD failure.
E228	Lower VFD Voltage Error	Lower VFD voltage does not correspond to jumper settings.	– Lower VFD voltage jumper is not correct. – Possible Lower VFD failure.
E289	Unknown Error from VFD	VFD has provided an unknown error.	– Possible VFD failure.
E290	Unknown Error from Lower VFD	Lower VFD has provided an unknown error.	– Possible Lower VFD failure.

Limited Warranty

Introduction Alto-Shaam, Inc. warrants to the original purchaser only, that any original part found to be defective in material or workmanship will be replaced with a new or rebuilt part at Alto-Shaam's option, subject to provisions hereinafter stated.

Warranty Period The original parts warranty period is as follows:

- For all other original parts, one (1) year from the date of installation of appliance or fifteen (15) months from the shipping date, whichever occurs first.
- The labor warranty period is one (1) year from the date of installation or fifteen (15) months from the shipping date, whichever occurs first.
- Alto-Shaam will bear normal labor charges performed during standard business hours, excluding overtime, holiday rates or any additional fees.
- For the refrigeration compressor, if installed, the warranty period is five (5) years from the date of original installation of the appliance.
- For heating elements on Halo Heat® Cook and Hold ovens, the warranty period is for as long as the original owner owns the oven. This warranty period applies to units sold after 2/1/2009 and excludes holding-only ovens.
- To be valid, a warranty claim must be asserted during the applicable warranty period. This warranty is not transferable.

Exclusions This warranty does not apply to:

- Calibration.
- Replacement of light bulbs, rubber gaskets, grease filters, air filters, racks, jet plates, and/ or the replacement of glass due to damage of any kind.
- Equipment damage caused by accident, shipping, improper installation or alteration.
- Equipment used under conditions of abuse, misuse, carelessness or abnormal conditions, including but not limited to, equipment subjected to harsh or inappropriate chemicals, including but not limited to, compounds containing chloride or quaternary salts, poor water quality, or equipment with missing or altered serial numbers.
- Equipment damage caused by use of any cleaning agents other than those recommended by Alto-Shaam, including but not limited to damage due to chlorine or other harmful chemicals.
- Any losses or damage resulting from malfunction, including loss of food product, revenue, or consequential or incidental damages of any kind.
- Equipment modified in any manner from original model, substitution of parts other than factory authorized parts, unauthorized removal of any parts including legs, or unauthorized addition of any parts.
- Equipment damage incurred as a direct result of poor water quality*, inadequate maintenance of steam generators and/or surfaces affected by water. Water quality and required maintenance of steam generating equipment is the responsibility of the owner/ operator.
- Equipment damage incurred as a result of not following the required maintenance schedule published in the manuals for the equipment.

Conclusion This warranty is exclusive and is in lieu of all other warranties, express or implied, including the implied warranties of merchantability and fitness for a particular purpose. No person except an officer of Alto-Shaam, Inc. is authorized to modify this warranty or to incur on behalf of Alto-Shaam any other obligation or liability in connection with Alto-Shaam equipment.

**Refer to the product spec sheet for water quality standards.*



W164 N9221 Water Street • P.O. Box 450 • Menomonee Falls, Wisconsin 53052-0450 • U.S.A.
Phone: 262.251.3800 800.558.8744 U.S.A./CANADA Fax: 262.251.7067 800.329.8744 U.S.A. only
www.alto-shaam.com



ALTO-SHAAM ASIA
Shanghai, China
Phone +86-21-6173 0336

ALTO-SHAAM CANADA
Concord, Ontario Canada
Toll Free Phone 866-577-4484
Phone +1-905-660-6781

**ALTO-SHAAM CENTRAL
& SOUTH AMERICA**
Miami, FL USA
Phone +1-954-655-5727

**ALTO-SHAAM MIDDLE EAST
& AFRICA**
Dubai, UAE
Phone +971 4 321 9712

ALTO-SHAAM MEXICO
Phone +52 1 477-717-3108

ALTO-SHAAM FRANCE, L.L.C.
Aix en Provence, France
Phone +33(0)4-88-78-21-73

ALTO-SHAAM GMBH
Bochum, Germany
Phone +49(0)234-298798-0

ALTO-SHAAM RUSSIA
Moscow, Russia
Phone +7-903-793-2331



Menomonee Falls, WI 53052-0450, U.S.A.
Telephone 800-558-8744 | +1-262-251-3800 | alto-shaam.com